

Features

- 2-way normally closed operation
- Die-cast aluminum bodies
- For positive shutoff on pilot or main gas lines of commercial and industrial gas burners.
- Valves provided with 1/8" NPT upstream and downstream pipe tap with plug for routine testing
- Suitable for ambient temperatures up to 175°F

Construction

Valve Parts in Contact with Fluids	
Body	Aluminum
Seals and Disc	NBR
Washer	302 Stainless Steel
Core Tube	305 Stainless Steel
Core and Plugnut	430F Stainless Steel
Core Guide	CA
Springs	302F Stainless Steel
Shading Coil	Copper
Pipe Plug	Zinc-Plated Steel

Electrical

Standard Coil and Class of Insulation	Watt Rating and Power Consumption			Ambient Temp. °F	Spare Coil Family	
	AC				General Purpose	Explosionproof
	Watts	VA Holding	VA Inrush		AC	AC
F	20	43	240	-40 to 175	222345	-

Standard Voltages: 24, 120, 240 volts AC, 60 Hz.
 K3A catalog number includes codification for voltage. However, voltage must be specified when ordering spare coil.

Solenoid Enclosures

Standard: Type 1 General Purpose Junction Box housing with two 7/8" knockouts.

Valve Response Time

Opening Time: Less than 1 second; **Closing Time:** Less than 1 second

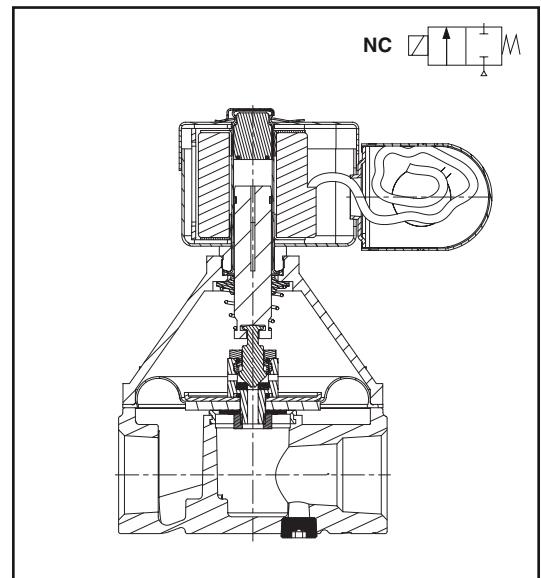

Approvals

UL listed to standard 429 "Electrically Operated Valves," Guide Y10Z, File MP932 Safety Valves.

FM Approved to Class 7400 "Liquid and Gas Safety Shutoff Valves" (3/4" only).

CSA Certified to:

- 1) Standard C22.2 No. 139 "Electrically Operated Valves," File 113070.
- 2) Automatic Gas Valves Z21.21 (6.5), File 109157 and 113070
- 2) Automatic Gas Safety Shutoff Valves C/I (3.9), File 113070

Specifications (English units)

Pipe Size (ins.)	Orifice Size (ins.)	Cv Flow Factor	Gas Capacity ① Btu/hr.	Operating Pressure Differential (psi)		Max. Fluid Temp. °F	Catalog Number			Const. Ref.	Agency			Wattage	Approx. Shipping Weight (lbs)
				Min.	Max.		24V 60 Hz	120V 60 Hz	240V 60 Hz		UL	FM	CSA		
COMBUSTION (Fuel Gas) - NORMALLY CLOSED															
3/4	1.25	12	667,000	0	5	77	K3A651U	K3A652U	K3A654U	1	○	○	○	20	4.5
1	1.25	17	960,000	0	5	77	K3A661U	K3A662U	K3A664U	1	○	-	○	20	4.7
1 1/4	1.75	23	1,290,000	0	5	77	K3A671U	K3A672U	K3A674U	2	○	-	○	20	4.5
1 1/2	1.75	27	1,509,000	0	5	77	K3A681U	K3A682U	K3A684U	2	○	-	○	20	4.7

○ = Safety Shutoff Valve. ① 1" W.C. Drop @ 2" W.C. Inlet Pressure, 1,000 Btu/cu.ft. or more, 0.64 Specific Gravity Gas.

Specifications (Metric units)

Pipe Size (ins.)	Orifice Size (mm)	Kv Flow (m³/hr)	Gas Capacity ① Btu/hr.	Operating Pressure Differential (bar)		Max. Fluid Temp. °C	Catalog Number			Const. Ref.	Agency			Wattage	Approx. Shipping Weight (kgs)
				Min.	Max.		24V 60 Hz	120V 60 Hz	240V 60 Hz		UL	FM	CSA		
COMBUSTION (Fuel Gas) - NORMALLY CLOSED															
3/4	32	12	667,000	0	0.3	25	K3A651U	K3A652U	K3A654U	1	○	○	○	20	2.0
1	32	17	960,000	0	0.3	25	K3A661U	K3A662U	K3A664U	1	○	-	○	20	2.1
1 1/4	44	23	1,290,000	0	0.3	25	K3A671U	K3A672U	K3A674U	2	○	-	○	20	2.0
1 1/2	44	27	1,509,000	0	0.3	25	K3A681U	K3A682U	K3A684U	2	○	-	○	20	2.1

○ = Safety Shutoff Valve. ① 1" W.C. Drop @ 2" W.C. Inlet Pressure, 1,000 Btu/cu.ft. or more, 0.64 Specific Gravity Gas.

Dimensions inches (mm)

Const. Ref.		H	J	K	L	M	N	P	R	T	W
1	ins.	6.33	3.53	4.14	4.00	2.50	5.53	5.46	2.00	2.19	3.87
	mm	161	90	105	102	64	140	139	51	56	98
2	ins.	7.03	3.53	4.47	5.19	2.50	6.15	5.78	2.62	2.19	3.87
	mm	179	90	114	132	64	156	147	67	56	98

Const. Ref. 1, 2

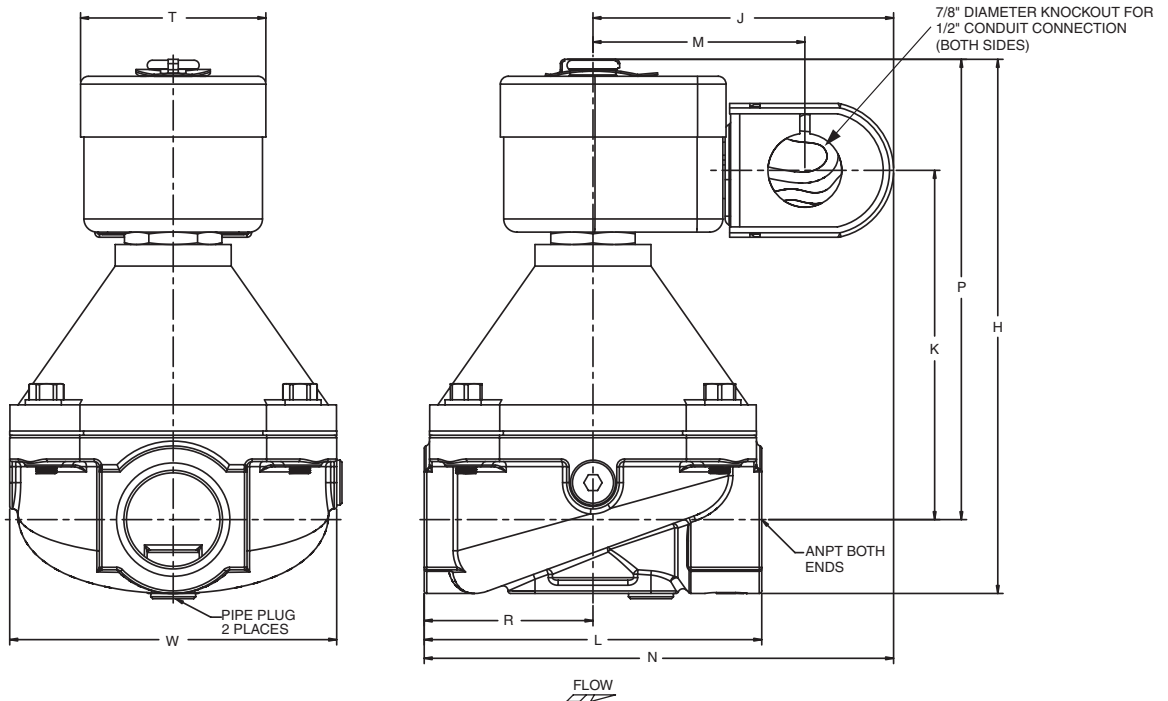

Must be mounted with solenoid vertical and upright or in the horizontal position.

